

# G2102 C CONVECTION OVEN RANGE G2112 C & G2112 C/2 CONVECTION OVENS



## USERS INSTRUCTIONS

SECTION 1 - GENERAL DESCRIPTION  
SECTION 2 - LIGHTING and OPERATIONS

SECTION 3 - COOKING HINTS  
SECTION 4 - CLEANING and MAINTENANCE

**These appliances have been CE-marked on the basis of compliance with the Gas Appliance Directive, EMC and Low Voltage Directive for the Countries, Gas Types and Pressures as stated on the Data Plate.**

These appliances MUST BE installed by a competent person in compliance with the INSTALLATION AND SERVICING INSTRUCTIONS and National Regulations in force at the time. Particular attention MUST be paid to the following:

**I.E.E. Regulations for Electrical Installations  
Gas Safety (Installation & Use) Regulations**

**Electricity at Work Regulations  
Health and Safety at Work Act**

Furthermore, if a need arises to convert the appliance for use with another gas, a competent person must be consulted. Those parts which have been protected by the manufacturer MUST NOT be adjusted by the User.

Users should be conversant with the appropriate provisions of the Fire Precautions Act and the requirements of the Gas Safety Regulations, in particular the need for regular servicing by a competent person to ensure the continued safe and efficient performance of the Appliance.

**WARNING - TO PREVENT SHOCKS, ALL APPLIANCES WHETHER GAS OR ELECTRIC, MUST BE EARTHED**

Upon receipt of the User's Instruction manual, the installer should instruct the responsible person(s) of the correct operation and maintenance of the Appliance.

This equipment is ONLY FOR PROFESSIONAL USE, and shall be operated by QUALIFIED persons. It is the responsibility of the Supervisor or equivalent to ensure that users wear SUITABLE PROTECTIVE CLOTHING and to draw attention to the fact that, some parts will, by necessity, become VERY HOT and will cause burns if touched accidentally.

### PREVENTATIVE MAINTENANCE CONTRACT

In order to obtain maximum performance from this unit we would recommend that a Maintenance Contract be arranged with SERVICELINE. Visits may then be made at agreed intervals to carry out adjustments and repairs. A quotation will be given upon request to the contact numbers below.



**WEEE Directive Registration No. WEE/DC0059TT/PRO**

At end of unit life, dispose of appliance and any replacement parts in a safe manner, via a licensed waste handler.

Units are designed to be dismantled easily and recycling of all material is encouraged whenever practicable.

### Falcon Foodservice Equipment

#### HEAD OFFICE AND WORKS

Wallace View, Hillfoots Road, Stirling, FK9 5PY, Scotland.

#### SERVICELINE

PHONE: 01438 363 000

**T100970 Ref.2**

## **SECTION 1 - GENERAL DESCRIPTION**

### **Training and competence**

To help ensure the safe use of this appliance there is a requirement for you to provide whatever information, instruction, training and supervision as is necessary to ensure, so far as is reasonably practicable, the health and safety of all users.

For further help and information on training and competence we would refer you the Health and Safety Executive website; [www.hse.gov.uk](http://www.hse.gov.uk) document ref: health and safety training INDG345. International customers should default to the health and safety guidelines provided by your government body.

### **Risk assessment**

As part of managing the health and safety of your business you must control any risks identified in your commercial kitchen. To do this you need to think about what might cause harm to people and decide whether you are taking reasonable steps to prevent that harm. This is known as risk assessment. It is important to consider the environment around the product as well as the product itself. For example oil or food spills will present a significant risk so users so the need to immediately clean up such spills must be reflected in staff training.

For further help and information on risk assessments we would refer you to you the Health and Safety Executive website; [www.hse.gov.uk](http://www.hse.gov.uk) document ref: risk assessment INDG163. International customers should default to the health and safety guidelines provided by your government body.

### **The Oven**

The oven has four grid shelves with safety stops on fixed position runners. One or more shelves can be removed to accommodate larger items, e.g. chickens.

The burner is situated below the oven compartment and heats it by conduction and convection. The air contained within the oven becomes heated by being circulated by the fan over a heat- exchanger in the base, and thence over the food, via holes in the oven side panels. This system promotes even heating throughout the oven, and in most cases lower temperatures than those necessary in conventional ovens can be used.

A cooking guide is provided which contains instructions for preparation of a wide variety of foods which can be cooked in this oven.

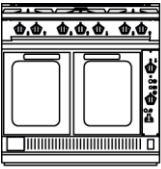

**G2102 C Open Top Convection Oven Range**

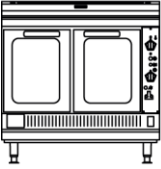

**G2112 C Convection Oven on Legs**

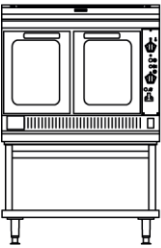

**G2112 C Convection Oven on Stand**

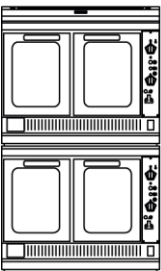

**G2112 C/2 Two Tier Convection Oven**

**Oven Controls**

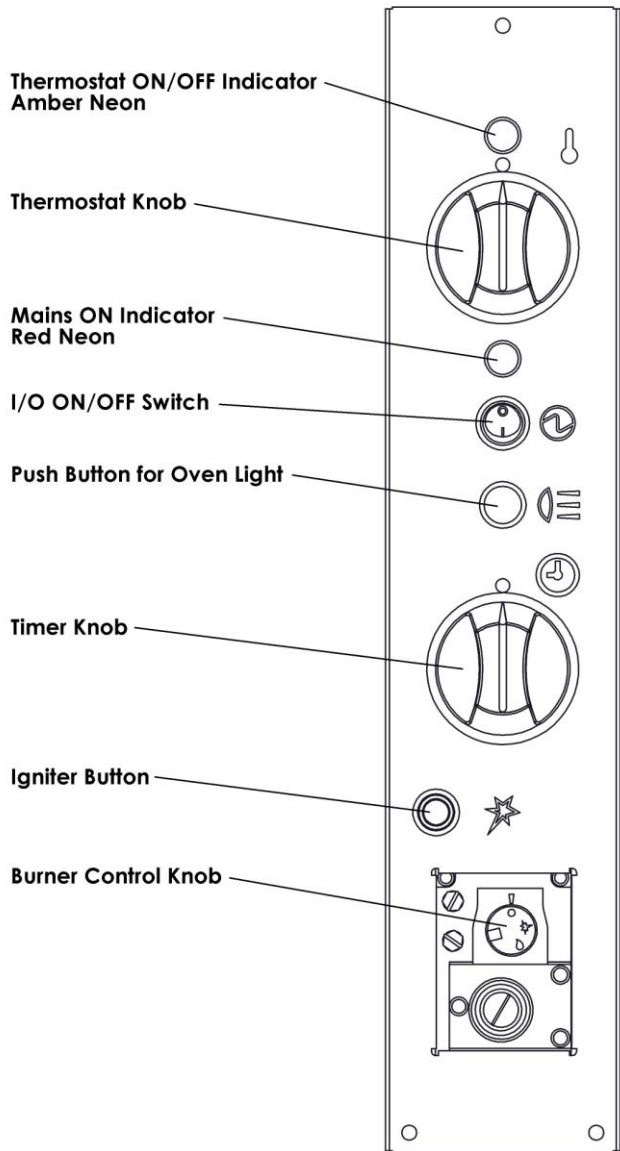

**Hob Controls (G2102 C model only)**

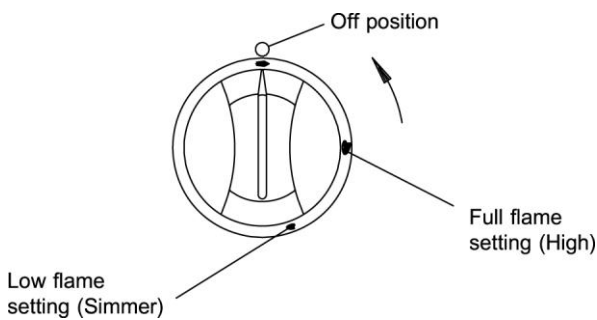

The controls are mounted on a panel at the RH side of the oven as shown above.

A door-operated micro-switch ensures the fans and burner are **turned off** whenever the doors are opened.

Each tap is identified to the corresponding burner by the icons below.

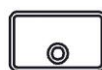

**Front Centre Burner**

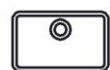

**Rear Centre Burner**

## SECTION 2 - LIGHTING and OPERATIONS

**Warning** – Never leave products that are in use unsupervised and always turn products off at the end of service.

### LIGHTING THE OVEN

#### Note

The gas control valve is fitted with a safety interlock. Therefore, a period of 3 minutes will elapse before it is possible to re-light after complete shut-down.

1. Turn thermostat knob and power switch to OFF and close oven doors.
2. Push in and turn burner control knob to pilot position then push in fully and hold while repeatedly pressing and releasing igniter button until pilot lights. Check pilot is lit by using the base mirror.
3. Keep control knob pressed in fully for a further 20 seconds before release. Pilot should remain lit but if it goes out; push in and turn burner control knob to OFF position and wait for three minutes. (Repeat from Step 2).
4. Push in and turn burner control knob to main burner position.
5. Set thermostat to desired setting and turn power switch to ON. Oven fan will turn on and oven burner will now light.

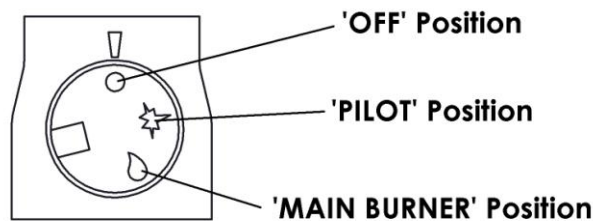

### Turning the Oven OFF

#### For Short Periods

Turn the thermostat to the OFF position. This will leave only the pilot alight.

#### For Longer Periods

1. Turn thermostat to OFF position.
2. Push in and turn burner control knob to OFF position.
3. Switch power I/O switch to OFF, or the fan will remain on.

This will turn both pilot and main burner OFF. To re-light, follow lighting instructions.

#### Timer

The timer knob is marked in minutes and should be set to required cooking time when food is placed in the oven. It should be turned fully clockwise then back to desired time.

When set time has elapsed, the warning buzzer will continuously ring until operator switches it OFF.

The timer does not switch off oven but provides an audible warning when cooking cycle is complete.

#### Oven Light

This illuminates oven from rear via push-button switch on control panel.

#### Pre-heating Time

Allow at least 45 mins from switching on a cold oven, irrespective of temperature setting. Insert the food as quickly as possible, and close the doors firmly.

### LIGHTING THE HOB (G2102 C Range Only)

1. Ensure mains gas is turned ON.
2. Push in and turn knob to FULL FLAME position.
3. Keep knob pressed in and manually light the burner. Continue to hold knob in for 20 seconds and release.
4. If burner fails to stay lit, wait for one minute, and then repeat steps 2 to 3 until it does.
5. When lit, turn knob to required setting.

## SECTION 3 - COOKING HINTS

### Warning

Care must be taken by the operator to avoid burns if opening the oven doors when chamber is hot.

### Using the Oven

When oven has reached working temperature, AMBER light will go out then operate ON/OFF as thermostat maintains temperature.

Opening doors or switching OFF power switch switches off fan and thermostat/burner.

### Loading

All four shelves can be used simultaneously and normally no manipulation of food on the shelves is necessary. Containers or food up to 75mm high can be cooked when using four shelves, but if food bigger than this is cooked i.e. chicken, one or more shelves can be removed as necessary. Shelves have stops to prevent accidental removal: to remove, lift stops above front of side runners.

When loading, oven doors should be kept open for as short a time as possible in order to minimise heat loss.

### Tray Size

The oven will accept 2/1 gastronorm trays (650 x 530mm) or conventional trays up to this size.

Trays and dishes must always be centrally placed on shelves.

### Cooking Charts

This information is provided as guidance only and all figures are approximate.

Miscellaneous	TEMP	TIME	No. of SHELVES
Cornish Pasties	190	30 mins	4
Roast Potatoes	200	30 mins	4
Baked Potatoes	215	45 mins	4
Tomatoes	190	8 to 10 mins	4
Toad in the Hole	215	30 mins	4
Baked Apples	200	30 mins	4
Yorkshire Pudding (Large)	240	25 mins	4

Meats	TEMP	TIME	No. of SHELVES
Lamb, Roast Beef, etc.	150-175	25 mins per 0.5kg	2
Chicken	150	1.8kg (4lbs) in 1 hour	2
Braised Steak	175	1 hour 30 mins – 2 hrs	4
Pork Chops	175	15 to 20 minutes	4
Lancashire Hotpot	175	1 hour 30 mins – 2 hrs	4

Baking	TEMP	TIME	No. of SHELVES
Scones and Small Buns	230	15 mins	4
Vol-au-Vent Cases	200	10 mins	4
Gingerbread, etc.	150	2 hours	4
Meringue (white)	100	2 hours 30 minutes	4
Shortbread	175	15 to 20 minutes	4
Biscuits	175	10 to 15 mins	4

Fish	TEMP	TIME	No. of SHELVES
Poached Haddock	175	45 mins	4

Puddings	TEMP	TIME	No. of SHELVES
Baked Rice	175	1 hr to 1 hr 15 minutes	4
Bakewell Tarts	190	30 to 45 minutes	4
Large Sponge Slab (25 – 38mm deep)	200	30 mins	4

### **Using the Open Top (G2102 C model only)**

Open top burners are rated at 5.3kW nett.

The pan supports will safely accommodate pans from 125mm diameter (minimum) to 380mm diameter (maximum).

#### **Note**

For maximum efficiency, place pan centrally over burner head and avoid flames licking up the pan side.

## **SECTION 4 - CLEANING and MAINTENANCE**

When removing heavy items to aid cleaning or maintenance particular care should be taken. A manual handling risk assessment is the best way to determine the level of risk to anyone using or maintaining this equipment. To help with such an evaluation we have included the weights of individual components that may present significant risk.

For further help and information on manual handling and associated risk assessment we would refer you to you the Health and Safety Executive website; [www.hse.gov.uk](http://www.hse.gov.uk) document ref: manual handling at work INDG143. International customers should default to the health and safety guidelines provided by your government body.

The cleaning of fryers or other products that use hot oil present significant risks to end users and particular care should be taken. Cold water and hot oil for example are an explosive mix and should be avoided at all costs.

Other useful references for health and safety issues

[www.hse.gov.uk](http://www.hse.gov.uk)

Essentials of health and safety at work ISBN978

Noise at work INDG362

Safe systems of work

Other notes added to the body of the instructions

#### **Important**

BEFORE CLEANING IS UNDERTAKEN, ISOLATE FROM MAINS ELECTRICITY SUPPLY. ENSURE APPLIANCE IS ADEQUATELY COOLED, TO AVOID BURNS. THE APPLIANCE MUST NOT BE CLEANED WITH A JET OF WATER OR STEAM CLEANED.

#### **Never clean products whilst they are hot.**

#### **General**

All surfaces are easier to clean if spillage is removed before it becomes burnt on.

All spills onto this product and on the floor should be cleaned up immediately.

Take care when removing cast iron components as they are heavy items.

#### **Pan Support – 5kg**

#### **Stainless Steel Surfaces**

These should be cleaned with hot water and detergent then dried and polished with a soft cloth.

Cleaning agents containing bleach, abrasives or caustic chemicals will damage or stain such a surface and must never be used.

#### **Vitreous Enamel Surfaces**

Approved cleaning agents which have the mark of the Vitreous Enamel Development Centre are recommended.

It is advisable to clean daily after use. Wipe clean the vitreous enamel surfaces while still warm, but not hot enough to cause burns, using a soft cloth and hot soapy water. Badly stained removable parts should be soaked in hot water with an approved detergent. If parts cannot be removed, the application of warm water with an approved detergent using nylon or scotch-cleaning pads will give good results.

## Oven

Oven shelves may be removed for cleaning by lifting stops over front side of runners, but the enamelled linings are not removable, except for servicing. Daily cleaning is best, preferably while the oven is still warm, but not hot enough to cause burns. Use of a proprietary detergent is the best general method. For stubborn deposits a proprietary oven cleaner may be used in accordance with the manufacturers' instructions. Before removing any part for cleaning, note how it is arranged and ensure that it is replaced correctly.

### Open Top (G2102 C only)

#### Pan Supports

Clean with warm soapy water. Abrasives such as fine steel wool, proprietary cleaning pads or nylon pan scrubbers, should be used with care and only in cases of extreme overspill. Dry off the pan supports by hand. NEVER LEAVE TO DRY NATURALLY.

After drying, apply a light film of vegetable oil. This will prevent oxidisation.

#### CLEANING INSTRUCTIONS for OPEN TOP BURNERS

The following instructions should be followed when:

- a) A spillage has occurred on the burner.
- b) The burner fails to light or remain lit.
- c) At the end of each day or cooking period.

#### Caution

Parts may be hot therefore it is recommended that parts be allowed to cool to a safe handling temperature to avoid burns.

1. Remove pan support.
2. Remove burner head and bezel by lifting upward.

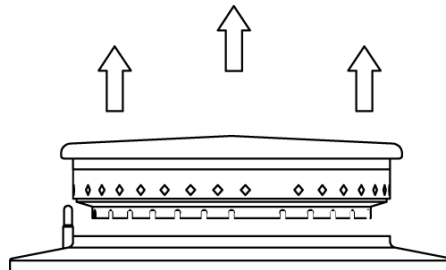

3. Thoroughly clean with soap and water. Ensure all burner ports are clean and free from food or cleaning material debris.

#### Important

Stubborn debris lodged in ports can be removed using a non-metallic implement such as a cocktail stick. The slots in the base should be freed of debris using a soft brush.

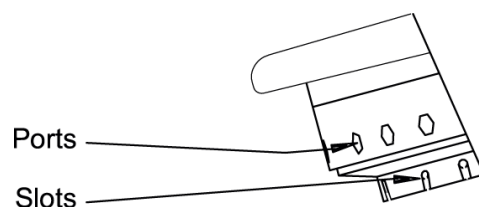

Dry burner with a lint-free cloth and blow through the ports to ensure there is no blockage.

4. Clean any spillage from burner base, ensuring all food debris and cleaning material is removed. Dry burner base thoroughly, taking care not to damage the flame sensor.

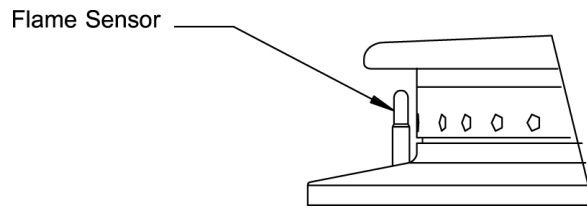

**Important**

Do not allow any spillage debris or cleaning material to enter the large hole in the burner base.

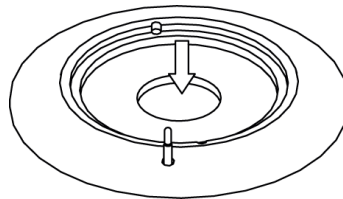

5. Replace aluminium bezel and burner head upon burner base and ensure the head location pips sit within the burner bezel notches. When burner head is properly located, it will not rotate.

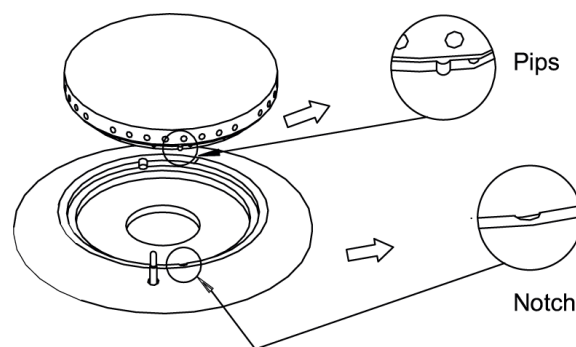

6. Light burner to check that it operates correctly.

**Note**

This process should be followed prior to calling for a Service Engineer. Failure due to lack of proper cleaning is not covered by warranty.